

Trilli 08/21/2018
Point Op 8/21/18
8/21/18

INSTALLATION INSTRUCTIONS FOR DCP-R2MH/R2ML DUAL RELAY MODULE

The information contained in this installation instruction is a quick reference guide. For detailed system information refer to the panel manufacturer's installation manual. This instruction will not address specific programming procedure.

GENERAL DESCRIPTION

This instruction applies to the programmable DCP Dual Relay Module (R2MH/R2ML) which is to be connected to a DCP Signaling Line Circuit (SLC). The R2MH/R2ML provide two separately controlled sets of Form C dry relay contacts for general purpose control functions at one address point. Typical applications are where normally open or normally closed contacts are needed. This module is suitable for Daily use as per UL864.

MOUNTING REQUIREMENTS

The DCP Relay module is mounted as shown in Figures 2 and 2A on page 2 of this instruction.

WIRING

NOTE: All wiring must conform to local codes, ordinances and regulations

- 1) Install module wiring in accordance with the job drawings and appropriate wiring diagram (see Fig.3).
- 2) Secure the module to a U.L. listed electrical box (supplied by installer), as shown in Figures 2 and 2A.
- 3) Address must be set before cover plate is attached with no loop power applied, or the loop wires disconnected (see Figure 1).

NOTE: An average of 6.75mA (communication current) per loop of SLC devices, must be factored into the panel battery backup calculations.

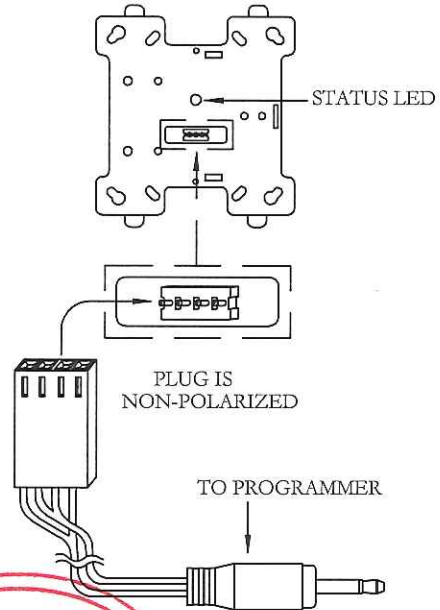
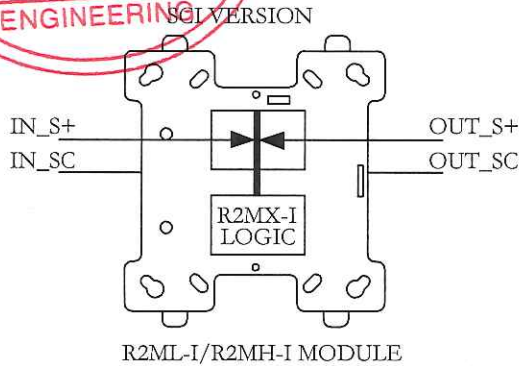

FIGURE 1. EXPLODED VIEW OF ADDRESS PROGRAMMING PLUG AND CONNECTOR

MODELS

R2MH and R2ML have versions with built-in SCI Short Circuit Isolator circuitry.

Module	Feature
DCP-R2ML-I	Integrated SCI
DCP-R2MH-I	Integrated SCI
DCP-R2ML	No SCI
DCP-R2MH	No SCI



INTEGRATED SCI SHORT CIRCUIT ISOLATOR OPERATION

The DCP-R2ML-I and DCP-R2MH-I modules have built-in integrated SCI circuitry. In the event of a short on the S-SC line, the SCI circuit will activate and its Yellow LED indicator will be turned on steady and the module will report the short circuit condition to the Fire Control Panel.

The SCI has a fast response time but the Control Panel will momentarily detect a short before the SCI circuit breaks open if the short occurs during normal operation. However, if the S-SC line was short before power-on, the Control Panel will only detect an open loop because the SCI switch circuit never closes. In that case, it will rely on the module to report a short.

The SCI circuit will prevent entire loop failure in case of a short. Upon removal of the short condition, the SCI will automatically restore the entire loop to normal operating state.

SPECIFICATIONS	
SLC Applied Voltage	Rated Range 25.3 - 39 VDC
SLC Current Consumption	Maximum - 720µA
Relay Contact Ratings	R2ML: 2A @ 30VDC 1PF OR 0.5A @ 120VAC 0.6PF R2MH: 8A @ 30VDC 1PF OR 250VAC Resistive, 4.8A @ 250VAC 0.6PF
SCI Isolation Current	10mA (Typical)
Visual Indicator (status LED)	Bi-color LED - Green and Red Color and mode - selected and programmed by Control Panel's software (pulsing, steady, etc.) Yellow Led - (SCI version only) Yellow LED on indicates SCI circuit is ACTIVE
Operating Temperature Range	0°C (32°F) ~ 49°C (120°F)
Storage Temperature	-30°C (-22°F) ~ 70°C (158°F)
Maximum Relative Humidity	Up to 90% RH non-condensing
Environment	For Dry Indoor Use Only
Dimensions	4.2"W X 4.7"H X .85"D

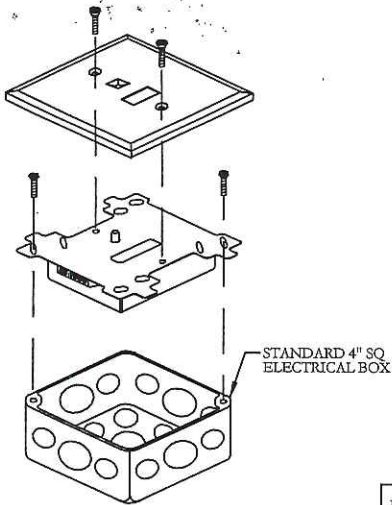

FIGURE 2
TYPICAL MOUNTING ARRANGEMENT
WHEN POWER LIMITED WIRING IS
ATTACHED TO RELAY TERMINALS

NOTE: ENSURE OVERCURRENT PROTECTION IS PROVIDED ON WIRING TO PREVENT FAULT CURRENTS IN EXCESS OF THE WIRE GAUGE CURRENT RATING PER NFPA 70 ARTICLE 240.

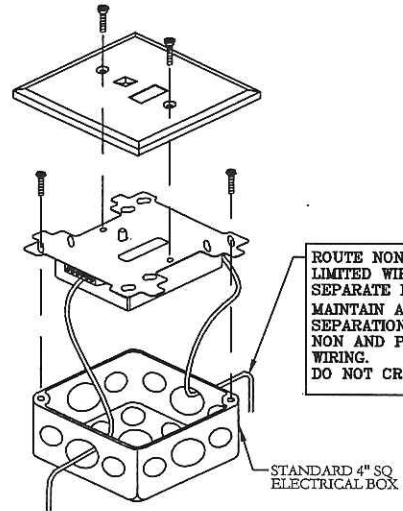

FIGURE 2A
TYPICAL MOUNTING ARRANGEMENT
WHEN NON-POWER LIMITED WIRING
IS ATTACHED TO RELAY TERMINALS

ROUTE NON-POWER LIMITED WIRING THROUGH SEPARATE KNOCKOUT. MAINTAIN AT LEAST 1/4 IN SEPARATION BETWEEN NON AND POWER LIMITED WIRING. DO NOT CROSS WIRING.

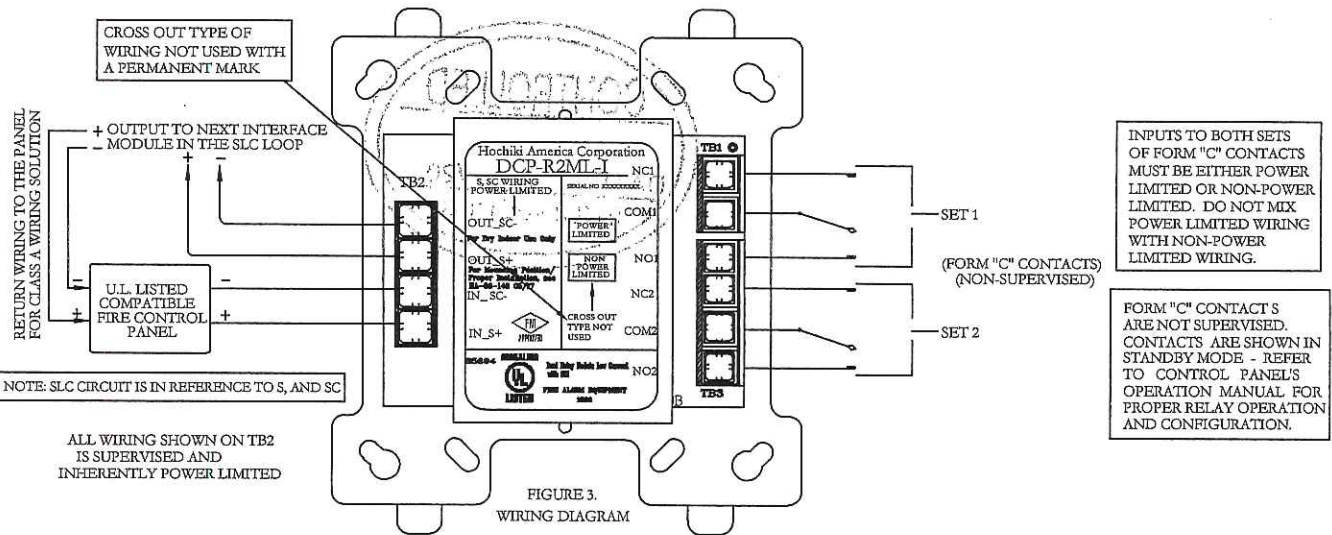

FIGURE 3.
WIRING DIAGRAM

CAUTION !!!
TO ENSURE PROPER OPERATION CONNECT THIS MODULE TO A COMPATIBLE FIRE CONTROL PANEL ONLY. REFER TO PANEL INSTRUCTIONS FOR PROPER CONNECTION AND COMPATIBILITY.

CAUTION !!!
If this module will be installed in an existing operational system, inform the operator and local authority that the system will be temporarily out of service. Disconnect power to the control panel before installing the module

NOTE: RELAY CONTACTS MAY HAVE TRANSFERRED DURING SHIPPING. TO ENSURE CONTACTS ARE IN CORRECT "NORMAL" STATE AS INDICATED IN REFERENCED WIRING DIAGRAM, A "RESET" COMMAND SHOULD BE INITIATED FROM THE CONTROL PANEL PRIOR TO CONNECTION OF CIRCUITS CONTROLLED BY THE MODULE.

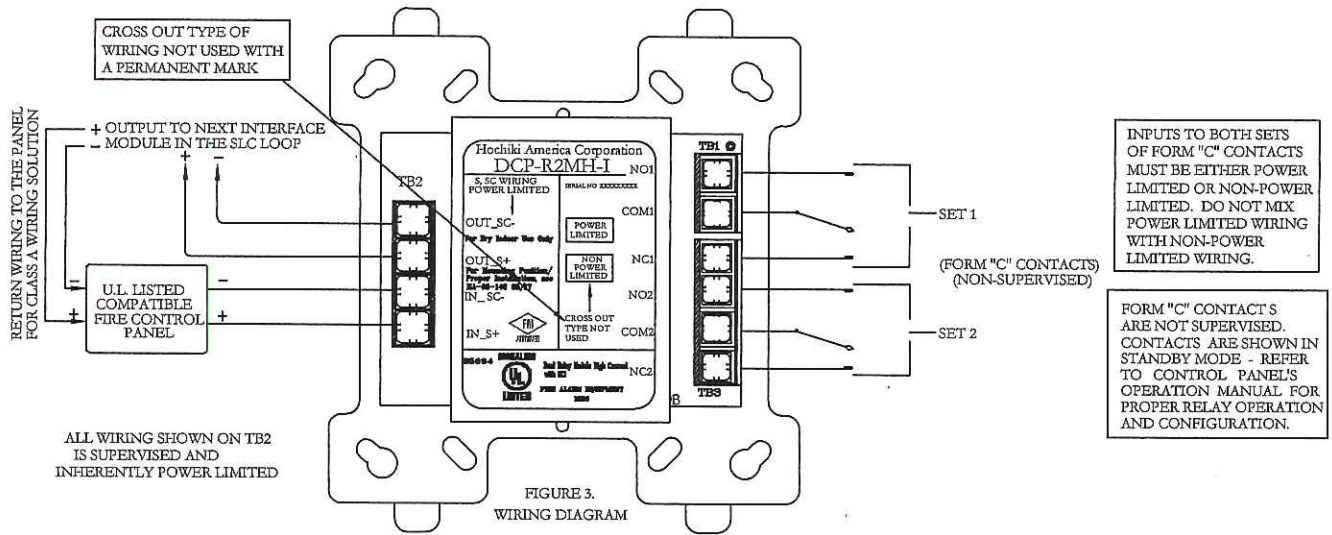

FIGURE 3.
WIRING DIAGRAM

One Year Limited Warranty

Hochiki America (HA) warrants its digital communication modules to be in conformance with its own plans and specifications and to be free from defects in materials and workmanship under normal use and service for a period of one (1) year from date of delivery. All warranties are void and HA is not obligated to repair or replace equipment which has been repaired by others, abused, improperly installed, altered or otherwise misused or damaged or exposed to conditions outside the products specifications in any way. HA will not be responsible for any dismantling, reassembling or re-installation charges. Please contact HA's Sales department for proper procedure for claims and return of merchandise. This warranty is in lieu of all other warranties expressed or implied.

DWG. # HA-06-148
(PG 2 OF 2, 05/17)
PART# 1700-10360